



**BUCKEYE TRACTOR CO**

## **Parts List**

**Model 2537-M  
MULCH LAYER**

same as 2537

Version B07 • Serial No. 4321887 • Effective 8-18-06

Serial No: \_\_\_\_\_ Date Received: \_\_\_ / \_\_\_ / \_\_\_

Purchased From: \_\_\_\_\_

Order / Invoice No: \_\_\_\_\_



**BUCKEYE TRACTOR CO**

**P.O.Box 97 • 11313 Slabtown Road • Columbus Grove, Ohio 45830 USA  
call 419-659-2162 • fax 419-659-2082**

**buckeyetractor@bright.net • www.buctraco.com**

***YOUR PURCHASE INCLUDES COMPLETE AFTER-SALE SERVICE***

# GALLERY



# PARTS LIST

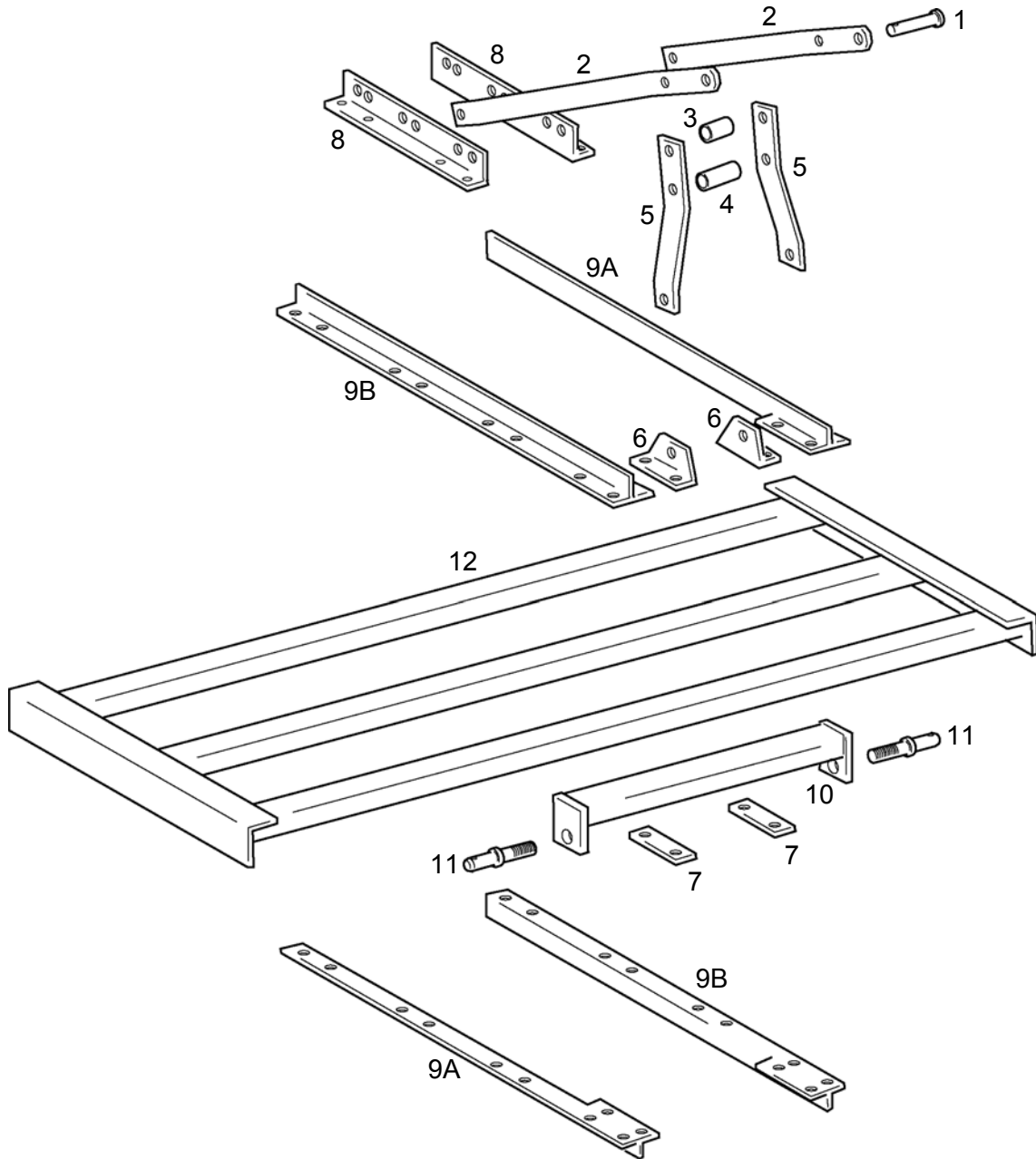

# PARTS LIST

Ref	Quan	Part No	Description	Price
	<b>1</b>	<b>22513</b>	<b>Toolbar Hitch - includes Ref 1 thru 11</b>	_____
1	1	517-516	Hitch Pin, 1 x 4-1/2	_____
	2	512-816	Linch Pin, 5/16	_____
2	2	517-656	Top Hitch Bar	_____
	1	511-012	Hex Capscrew, 3/4-10 x 6	_____
	2	511-103	Hex Capscrew, 3/4-10 x 1-3/4	_____
	3	511-172	Hex Nut, 3/4-10	_____
3	1	517-091	Bushing, 1-1/8 OD x 3/4 ID x 2-1/2	_____
4	1	517-092	Bushing, 1-1/8 OD x 3/4 ID x 3-3/4	_____
	1	511-012	Hex Capscrew, 3/4-10 x 6	_____
	1	511-172	Hex Nut, 3/4-10	_____
5	2	517-696	A-Frame Support	_____
	2	511-103	Hex Capscrew, 3/4-10 x 1-3/4	_____
	2	511-172	Hex Nut, 3/4-10	_____
6	2	517-093	Anchor Bracket	_____
	4	511-029	Hex Capscrew, 5/8-11 x 3-1/2	_____
	4	511-142	Hex Nut, 5/8-11	_____
7	2	517-095	Clamp Bar	_____
8	2	517-087	Rear Anchor Bracket	_____
	4	511-121	U-Bolt, 1/2-13 x 2sq x 3	_____
	8	511-051	Hex Nut, 1/2-13	_____
9A	1	514-310	Hitch Clamp Bar, 3-bar Side A	_____
9B	1	514-304	Hitch Clamp Bar, 3-bar Side B	_____
	12	511-029	Hex Capscrew, 5/8-11 x 3-1/2	_____
	12	511-142	Hex Nut, 5/8-11	_____
10	1	517-111	Lower Hitch Crossbar	_____
	8	511-029	Hex Capscrew, 5/8-11 x 3-1/2	_____
	8	511-142	Hex Nut, 5/8-11	_____
11	2	511-653	Anchor Pin	_____
	2	511-362	Linch Pin, 7/16	_____
	2	510-966	Hex Nut, 1-1/8-12	_____
			<b>ADD (1) Toolbar Frame to Toolbar Hitch</b>	
12	1	20043-084	Toolbar Frame, 2sq x 3-bar x 84 x 1/4w - standard on 2537	_____

# PARTS LIST

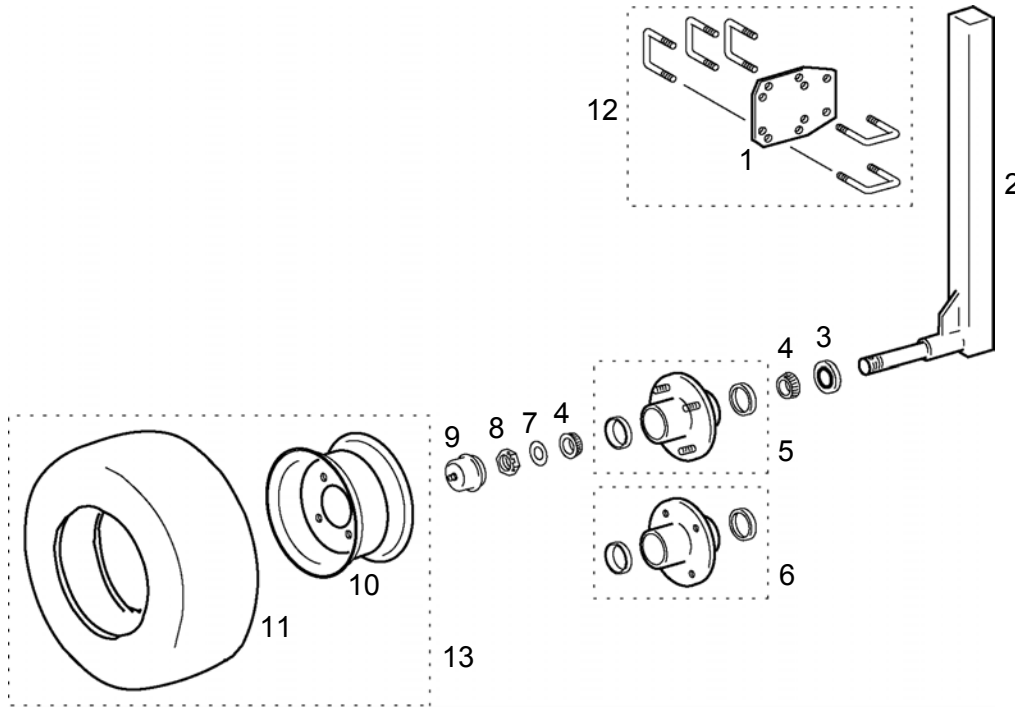

Ref	Quan	Part No	Description	Price
	<b>1</b>	<b>18172</b>	<b>Gauge Wheel Asby, 18x850-8, Pair for 2sq - includes Ref 1 thru 11</b>	_____
1	2	518-582	D5-Plate, 2 x 2	_____
	10	511-121	U-Bolt, 1/2-13 x 2sq x 3	_____
	20	511-051	Hex Nut, 1/2-13	_____
2	2	517-169	Shank & Spindle	_____
3	2	511-759	Seal	_____
4	2	511-715	Bearing Cone, L44643	_____
5	2	514-284	Hub w/ Bearing Cups & Studs - alternate to 514-294	_____
	2	510-793	Grease Fitting, 1/4-28 90-deg - early part	_____
	2	511-478	Bearing Cup, L44610 - included	_____
	4	514-291	Stud - included	_____
6	2	514-294	Hub w/ Tapped Holes - alternate to 514-284	_____
	2	510-793	Grease Fitting, 1/4-28 90-deg - early part	_____
	2	511-478	Bearing Cup, L44610 - included	_____
7	2	511-714	Spindle Washer, 1"-10ga	_____
8	2	511-425	Spindle Nut, 1-14 Slotted Jam	_____
	2	511-758	Spindle Pin, 5/32 x 1-1/4	_____

# PARTS LIST

Ref	Quan	Part No	Description	Price
9	2	511-424	Dust Cap	_____
	2	510-846	Grease Fitting, 1/4-28 Straight - included	_____
10	2	517-167	Wheel, 8x7, 4-bolt, 4" backspacing	_____
	2	515-581	Valve Stem - included	_____
	2	514-286	Valve - included	_____
	2	514-287	Cap - included	_____
	8	510-954	Lug Bolt, 1/2-20 x 1- alternate to 510-792	_____
	8	510-792	Lug Nut, 1/2-20 - alternate to 510-954	_____
11	2	517-168	Tire, 18x850-8	_____
<b>Parts assemblies w/ related fasteners</b>				
12	2	20205E	D5-Clamp Asby, 2sq x 2sq	_____
13	2	517-166	Wheel Asby, 18x850-8	_____
<b>Early parts</b>				
14	2	517-300	D-Plate, 2 x 2	_____

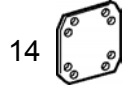

# PARTS LIST

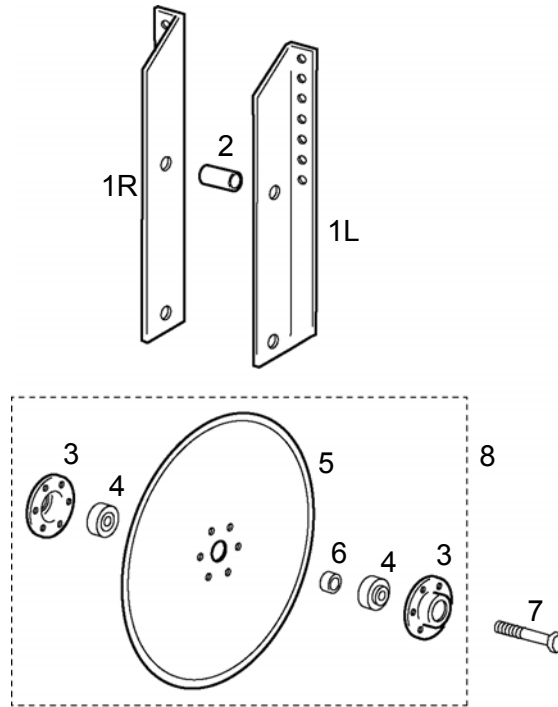

Ref	Quan	Part No	Description	Price
	<b>1</b>	<b>18350</b>	<b>Rigid Coupler, 18" &amp; Shank Asby - includes Ref 1 thru 7</b>	_____
1L	1	518-347	Rigid Coupler Shank, Left	_____
1R	1	518-348	Rigid Coupler Shank, Right	_____
	2	511-121	U-Bolt, 1/2-13 x 2sq x 3	_____
	4	511-051	Hex Nut, 1/2-13	_____
2	1	518-333	Spacer, 1-1/8 OD x 3/4 ID x 2-1/4	_____
	1	511-018	Hex Capscrew, 3/4-10 x 3-1/2	_____
	1	511-172	Hex Nut, 3/4-10	_____
3	2	517-912	Hub Flange	_____
	6	510-709	Hex Capscrew, 5/16-18 x 7/8	_____
	6	511-240	Hex NyLock Nut, 5/16-18	_____
4	2	517-919	Ball Bearing, 205RVA, John Deere A27002	_____
5	1	518-220	Coupler Blade, 18"	_____
6	1	518-461	Spacer, 1-1/8 OD x 3/4 ID x 0.460	_____
7	1	511-018	[Bearing Bolt] Hex Capscrew, 3/4-10 x 3-1/2	_____
	1	511-172	Hex Nut, 3/4-10	_____
			<b>Parts assembly w/ related fasteners</b>	
8	1	518-171	Coupler & Hub Asby	_____

# PARTS LIST

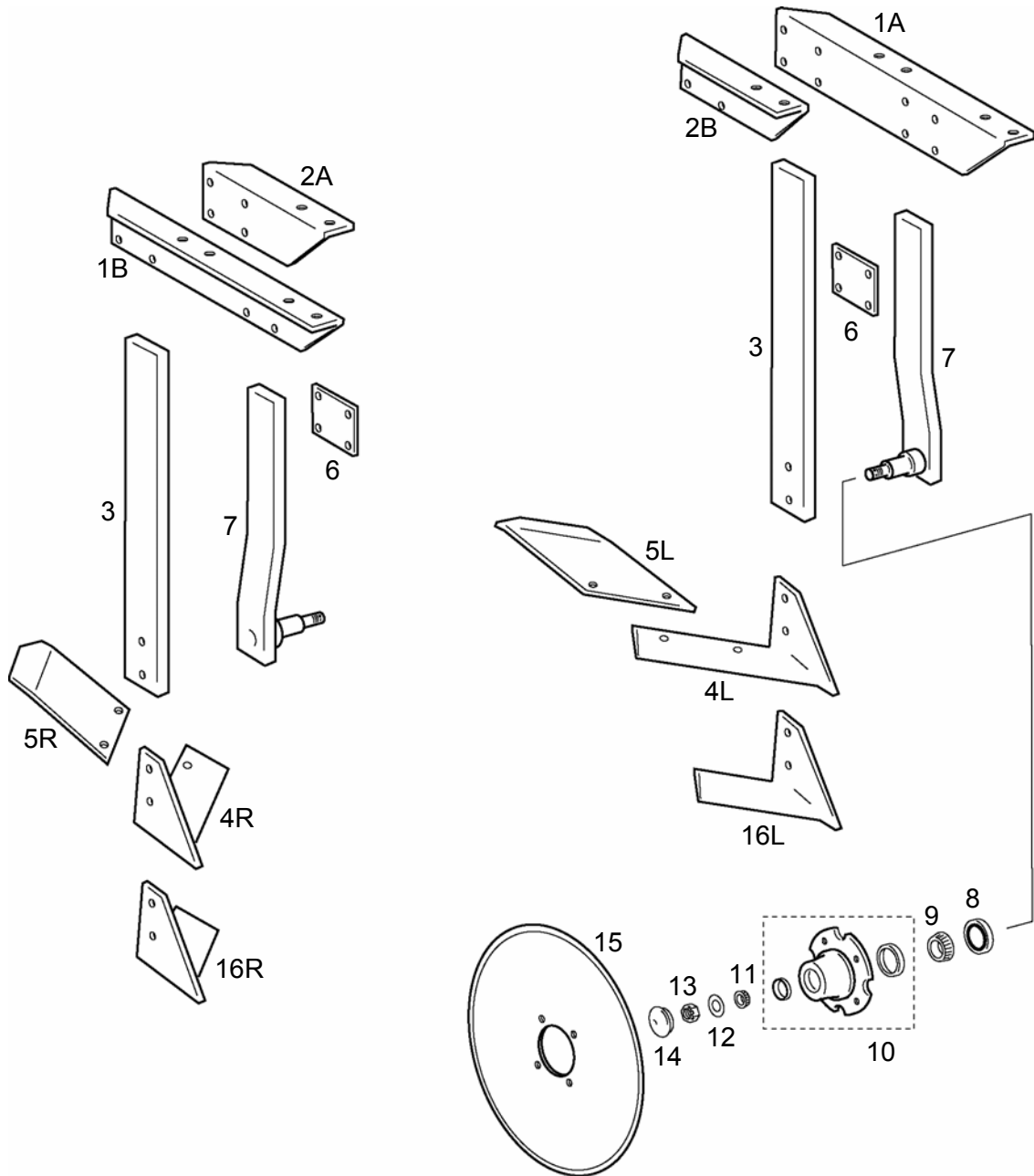



# PARTS LIST

Ref	Quan	Part No	Description	Price
	1	18410	<b>Lifter Shank &amp; Coulter, L&amp;R for 2-bar x 2sq - includes Ref 1 thru 7</b>	_____
1A	1	518-403	Shank Half Bracket, 2-Bar Side A	_____
1B	1	518-404	Shank Half Bracket, 2-Bar Side B	_____
	4	511-121	U-Bolt, 1/2-13 x 2sq x 3	_____
	8	511-051	Hex Nut, 1/2-13	_____
2A	1	518-401	Shank Half Bracket, Side A	_____
2B	1	518-402	Shank Half Bracket, Side B	_____
	2	511-121	U-Bolt, 1/2-13 x 2sq x 3	_____
	4	511-051	Hex Nut, 1/2-13	_____
3	1	518-190	Shank	_____
	4	516-518	Shear Bolt, 1/2-13 x 2-1/2	_____
	4	511-065	Hex Capscrew, 1/2-13 x 2-1/2	_____
	8	511-065	Hex Nut, 1/2-13	_____
4L	1	517-461	Lifter Sweep, Left	_____
4R	1	517-462	Lifter Sweep, Right	_____
	4	511-067	Hex Capscrew, 1/2-13 x 2	_____
	4	511-051	Hex Nut, 1/2-13	_____
5L	1	517-707	Heave Plate, Left	_____
5R	1	517-708	Heave Plate, Right	_____
	4	510-722	Clipped Head Plow Bolt, 7/16-14 x 1-1/4	_____
	4	511-007	Hex Nut, 7/16-14	_____
6	2	518-406	Clamp Plate	_____
	8	511-065	Hex Capscrew, 1/2-13 x 2-1/2	_____
	8	511-051	Hex Nut, 1/2-13	_____
7	2	518-580	Offset Coulter Shank & Spindle	_____
8	2	515-432	Seal	_____
9	4	517-772	Bearing Cone, LM67048	_____
10	2	517-890	Hub, 4-bolt w/ Bearing Cups, Tapped Holes	_____
	2		Bearing Cup, L44610 - included	_____
	2	515-400	Bearing Cup, LM11910 - included	_____
	2	510-846	Grease Fitting, 1/4-28 - included	_____
11	2	515-399	Bearing Cone, LM11949	_____
12	2	517-896	Spindle Washer, 3/4-10ga	_____
13	2	514-781	Spindle Nut, 3/4-16 Slotted	_____
	2	511-757	Spindle Pin, 5/32 x 1	_____
14	2	517-895	Dust Cap	_____
15	2	515-431	Coulter Blade, 18 x 5 or 5-1/4 circle	_____
	8	510-769	Hex Capscrew, 1/2-20 x 3/4	_____
	8	511-184	Flat Washer, 1/2 SAE	_____

# PARTS LIST

Ref	Quan	Part No	Description	Price
<b>OPTIONS</b>				
16L	1	518-161	Lifter Sweep, Left	_____
16R	1	518-162	Lifter Sweep, Right	_____

## EARLY PARTS

17	2	518-405	Offset Coulter Shank & Spindle	_____
18	2	515-432	Seal	_____
19	4	511-715	Bearing Cone, L44643	_____
20	2	515-433	Hub, 4-bolt w/ Bearing Cups, Tapped Holes	_____
	4	511-478	Bearing Cup, L44610 - included	_____
	2	510-846	Grease Fitting, 1/4-28 - included	_____
21	2	511-179	[Spindle Washer] Flat Washer, 5/8 SAE	_____
22	2	511-425	Hex Nut, 1-14 Slotted Jam	_____
	2	511-758	Cotter Pin, 5/32 x 1-1/4	_____
23	2	511-424	Dust Cap	_____

